

www.activconsole.com

# ACTIVCONSOLE

ERGONOMIC TECHNOLOGY

by AME System



ERGONOMIC TECHNOLOGY  
EDITION 2.0



AME System is an Australian owned company based in Melbourne, Victoria for the past 25 years. We have been designing and manufacturing ergonomic solutions for our ActivConsole range for some of the largest corporations both Australia-wide and internationally.

As a leading manufacturer of electric height adjustable workstations, we do our utmost to ensure that all of our designs are as practical, functional and aesthetically pleasing as possible. Incorporating the best practice in ergonomics & design, we utilise sophisticated materials and manufacturing techniques in all of our products, ensuring that you get the most out of your investment.

AME System Pty Ltd  
3/4 Garden Road  
Clayton Victoria 3168  
Australia  
Ph: +613 9574 8044  
Fax: +613 9574 8744

[sales@amesystem.com.au](mailto:sales@amesystem.com.au)  
[www.amesystem.com.au](http://www.amesystem.com.au)

[sales@activconsole.com](mailto:sales@activconsole.com)  
[www.activconsole.com](http://www.activconsole.com)

**ACTIVCONSOLE**  
ERGONOMIC TECHNOLOGY

by AME System



# TABLE OF CONTENTS

## STANDARD CONSOLES PAGES 4-23

Compact  
Premium  
Elite 'S'  
Ultimate  
Elite 'D'  
Ultimate 3L  
Executive  
Viewline  
Bench Top Dimensions

## CUSTOM DESIGNED CONSOLES PAGES 24-33

Custom designed, electric height adjustable control room consoles

## ACCESSORIES PAGES 34-45

Monitor Poles  
Monitor Supports  
Monitor Mounting Arms  
Cable Management Systems  
Footrest  
PC Holders  
Soft Wiring Systems & Devices  
Operator Chairs



## STANDARD CONSOLES

### COMPACT SERIES

- Λ Model 1811
- Λ Model 2011

Custom Sizes Available On Request

SEE PAGE 6



### PREMIUM SERIES

- Λ Model 2211
- Λ Model 2411

Custom Sizes Available On Request

SEE PAGE 8



### ELITE 'S' SERIES

- Λ Model 1910
- Λ Model 2110
- Λ Model 2310

Custom Sizes Available On Request

SEE PAGE 10



### ULTIMATE SERIES

- Λ Model 2012
- Λ Model 2212
- Λ Model 2412

Custom Sizes Available On Request

SEE PAGE 12







## STANDARD CONSOLES

### ELITE 'D' SERIES

- Λ Model 2015
- Λ Model 2215
- Λ Model 2415

Custom Sizes Available On Request

SEE PAGE 14



### ULTIMATE 3L SERIES

- Λ Model 2216
- Λ Model 2416
- Λ Model 2617

Custom Sizes Available On Request

SEE PAGE 16



### EXECUTIVE SERIES

- Λ Model 2110
- Λ Model 2310
- Λ Model 2510

Custom Sizes Available On Request

SEE PAGE 18



### VIEWLINE SERIES

- Λ Model 1690
- Λ Model 1810

Custom Sizes Available On Request

SEE PAGE 20





---

## COMPACT SERIES

---

Electrically Height Adjustable Control Room Console For Sit/Stand Operation

Standard Models Available:

Model 1811  
1800x1100

Model 2011  
2000x1100

Custom Sizes Available On Request



Developed for the control room environment where space is limited and cost is a factor, yet multiple monitors and hardware is necessary.



Specifications:

- Λ Two electric actuators, lifting capacity 100kg
- Λ Height range 680-1350mm, speed 43mm/sec at minimum load
- Λ Strong & lightweight aluminium frame, finish: anodised
- Λ Electrical power duct with 6 outlets
- Λ Two side mount PC holdrest
- Λ Built in manually adjustable foot rest
- Λ Inbuilt flexible cable management & cable tray
- Λ Thermoformed vinyl wrap bench tops
- Λ Set of rear/side removable panels

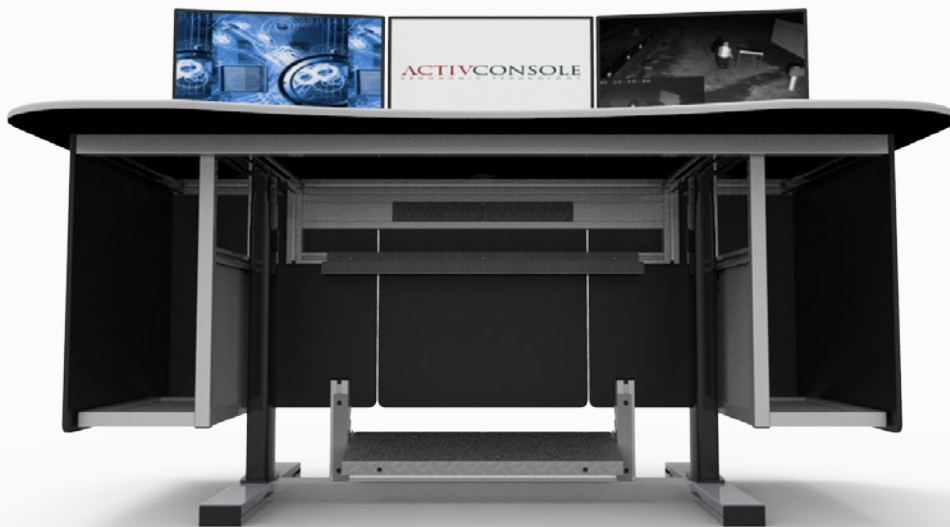
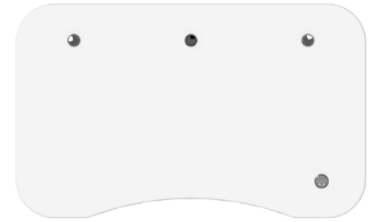



---

## PREMIUM SERIES

---

Electrically Height Adjustable Control Room Console For Sit/Stand Operation

Standard Models Available:

**Model 2211**  
2200x1100  
(curved or straight available)

**Model 2411**  
2400x1100  
(curved or straight available)

Custom Sizes Available On Request



Developed for the control room environment where situational awareness is paramount. An increased allowance for multiple monitors and PCs ensures the capability for a watchful eye in all conditions.



Specifications:

- Λ Four electric actuators, lifting capacity 180kg
- Λ Height range 680-1350mm, speed 43 mm/sec at minimum load
- Λ Strong & lightweight aluminium frame, finish: anodised
- Λ Electrical power duct with up to 10 outlets
- Λ Two side mount PC holders
- Λ Built in manually adjustable foot rest
- Λ Inbuilt flexible cable management & cable tray
- Λ Thermoformed vinyl wrap bench top
- Λ Set of rear/side removable panels







## ELITE 'S' SERIES

Electrically Height Adjustable Control Room Console For Sit/Stand Operation

Standard Models Available:

**Model 1810**  
1800x1000  
(curved or straight available)

**Model 2010**  
2000x1000  
(curved or straight available)

**Model 2210**  
2200x1000  
(curved or straight available)

Custom Sizes Available On Request



Developed for control room environments where operators, aesthetics and technology are all equally important. Single level adjustment with an enclosed base cabinet keeps your console clear and comfortable at all times.



Specifications:

- Λ Two electric actuators, lifting capacity 100kg
- Λ Electric adjustable operator surface
- Λ Height range 680-1350mm, speed 43 mm/sec at minimum load
- Λ Strong & lightweight aluminium frame, finish: anodised
- Λ Electrical power duct with up to 18 outlets (split circuits)
- Λ Floor mounted storage cabinet with front and rear access
- Λ Inbuilt flexible cable management
- Λ Thermoformed vinyl wrap bench top
- Λ Set of rear/side removable panels





## ULTIMATE SERIES

Electrically Height Adjustable Control Room Console For Sit/Stand Operation

Standard Models Available:

**Model 2012**  
2000x1200  
(curved or straight available)

**Model 2212**  
2200x1200  
(curved or straight available)

**Model 2412**  
2400x1200  
(curved or straight available)

Custom Sizes Available On Request



Developed for control room environments where increased monitoring equipment is required. Independent dual level adjustment allows the operators to be as comfortable as possible whilst maintaining clear vision at all times.



Specifications:

- Λ Four electric actuators, lifting capacity 100kg
- Λ Height range 680-1350mm, speed 43 mm/sec at minimum load
- Λ Strong & lightweight aluminium frame, finish: anodised
- Λ Dual level, independently adjustable operator surfaces
- Λ Electrical power duct with up to 10 outlets
- Λ Rear mount PC holder (max 2 pcs)
- Λ Built in manually adjustable foot rest
- Λ Inbuilt flexible cable management
- Λ Thermoformed vinyl wrap bench top
- Λ Set of rear/side removable panels

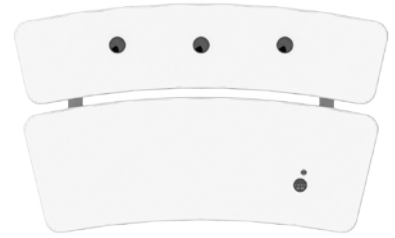



## ELITE 'D' SERIES

Electrically Height Adjustable Control Room Console For Sit/Stand Operation

Standard Models Available:

**Model 2015**  
2000x1500  
(curved or straight available)

**Model 2215**  
2200x1500  
(curved or straight available)

**Model 2415**  
2400x1500  
(curved or straight available)

Custom Sizes Available On Request



Developed for control room environments where operators, aesthetics and technology are equally important. Independent dual level adjustment with an enclosed base cabinet keeps your console clear and comfortable, whilst the individually height adjustable second level maintains clear vision at all times.





Specifications:

- Λ Four electric actuators, lifting capacity 100kg/level (2010 model only)
- Λ Five electric actuators, lifting capacity 100kg/level (2210 & 2410)
- Λ Electric adjustable monitor and operator surface
- Λ Height range 680-1350mm, speed 43 mm/sec at minimum load
- Λ Strong & lightweight aluminium frame, finish: anodised
- Λ Electrical power duct with up to 18 outlets (split circuits)
- Λ Floor mounted storage cabinet with front and rear access
- Λ Inbuilt flexible cable management
- Λ Thermoformed vinyl wrap bench top

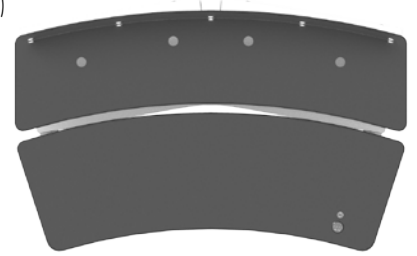



## ULTIMATE 3L SERIES

Electrically Height Adjustable Control Room Console For Sit/Stand Operation

Standard Models Available:

**Model 2216**  
2200x1600  
(curved or straight available)

**Model 2416**  
2400x1650  
(curved or straight available)

**Model 2617**  
2600x1700  
(curved or straight available)

Custom Sizes Available On Request



Developed for the control room environment where operator comfort and monitoring flexibility is paramount whilst heavily monitoring. Independent triple level adjustment allows the operators to be as comfortable as possible and still maintain clear vision at all times.



Specifications:

- Λ Seven electric actuators, lifting capacity 100kg/level
- Λ Triple level, independently adjustable operator surfaces
- Λ Height range 680-1350mm, speed 43 mm/sec at minimum load
- Λ Strong & lightweight aluminium frame, finish: anodised
- Λ Electrical power duct with up to 14 outlets
- Λ Two rear mount PC holders
- Λ Free standing manually adjustable foot rest
- Λ Inbuilt flexible cable management
- Λ Thermoformed vinyl wrap bench top
- Λ Set of rear/side removable panels

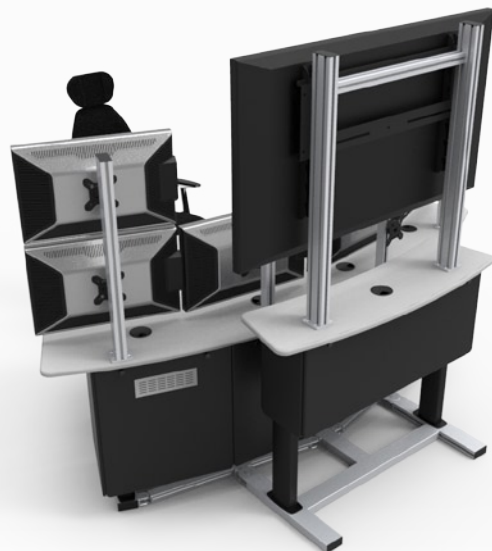



## EXECUTIVE SERIES

Electrically Height Adjustable Control Room Console For Sit/Stand Operation

Standard Models Available:

**Model 2110**  
2100x1000  
(bench top size)

**Model 2310**  
2300x1000  
(bench top size)

**Model 2510**  
2500x1000  
(bench top size)

Custom Sizes Available On Request



Developed for the control room environment where heavy monitoring, operator comfort and storage capability are important. Single level adjustment & sliding drawer cabinets with plenty of storage ensures monitoring flexibility, operator comfort and a clean, tidy work surface at all times.



Specifications:

- Λ Four electric actuators, lifting capacity 180kg
- Λ Height range 680-1350mm, speed 43 mm/sec at minimum load
- Λ Strong & lightweight aluminium frame, finish: anodised
- Λ Hidden electrical power duct with up to 22 outlets (split circuits)
- Λ Two external facing operator outlets on front of console
- Λ Dual side PC sliding cabinets (max 2 pcs)
- Λ Dual side sliding stationary drawers
- Λ Inbuilt flexible cable management
- Λ Thermoformed vinyl wrap bench top

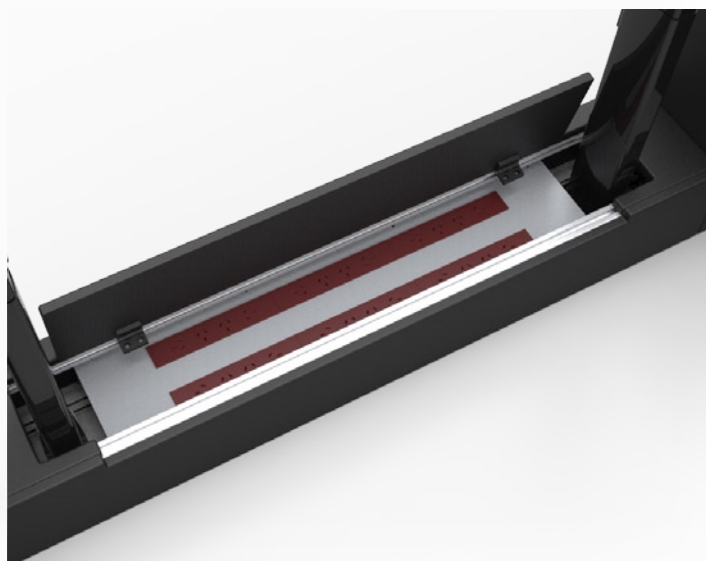
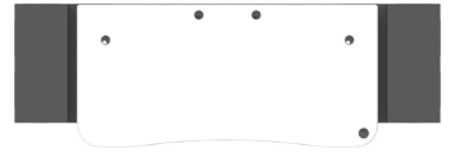





## VIEWLINE SERIES

Electrically Height Adjustable Control Room Console For Sit/Stand Operation

Standard Models Available:

**Model 1690**  
1600x900

**Model 1810**  
1800x1000



Developed around touch screen technology for an environment where a constantly clear line of sight is required (ie. airport apron, train platform, etc). Operator comfort at its highest, vision control at its best.



Specifications:

- Λ Four electric actuators, lifting capacity 100kg
- Λ Single level adjustment with dropped monitor surface
- Λ Two hidden side PC cabinets with sliding door access
- Λ Height range 680-1350mm, speed 43 mm/sec at minimum load
- Λ Strong & lightweight aluminium frame, finish: anodised
- Λ Electrical power duct with up to 10 outlets
- Λ Inbuilt flexible cable management
- Λ Thermoformed vinyl wrap sandwich bench top
- Λ Set of rear/front removable panels

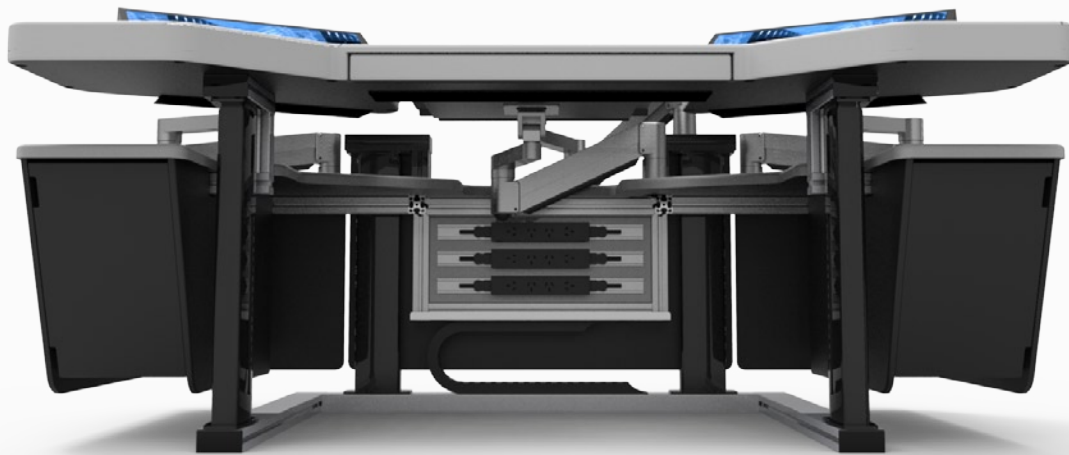
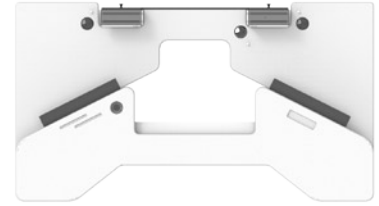



# STANDARD CONSOLES

models & bench top dimensions

## Compact Series

model 1811  
model 2011

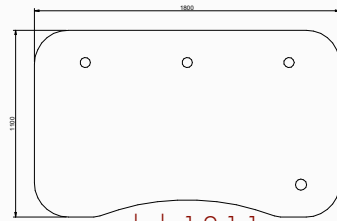

model 1811  
(bench top size 1800x1100)

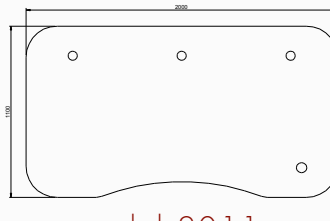

model 2011  
(bench top size 2000x1100)

## Premium Series

model 2211  
model 2411

(straight options available)

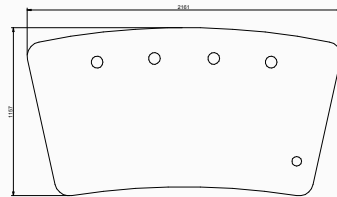

model 2211  
(bench top size 2200x1150)

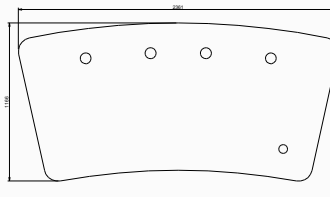

model 2411  
(bench top size 2400x1150)

## Elite S Series

model 1910  
model 2110  
model 2310

(straight options available)

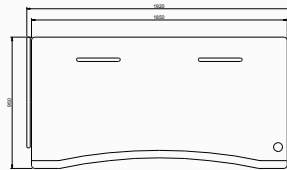

model 1910  
(bench top size 1900x1000)

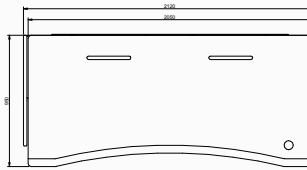

model 2110  
(bench top size 2100x1000)

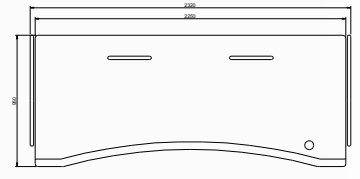

model 2310  
(bench top size 2300x1000)

## Ultimate Series

model 2012  
model 2212  
model 2412

(straight options available)

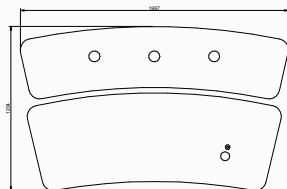

model 2012  
(bench top size 2000x1200)

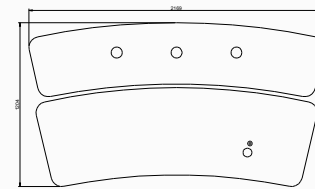

model 2212  
(bench top size 2200x1200)

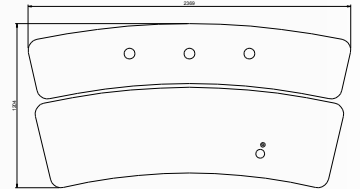

model 2412  
(bench top size 2400x1200)

## Elite D Series

model 2015  
model 2215  
model 2415

(straight options available)

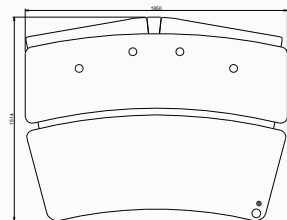

model 2015  
(bench top size 2000x1500)

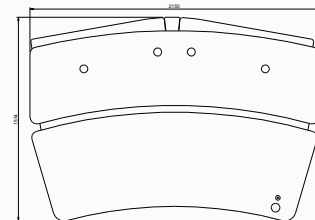

model 2215  
(bench top size 2200x1500)

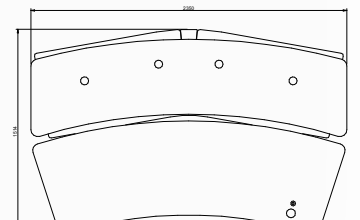

model 2415  
(bench top size 2200x1500)

All dimensions are approximate only. Actual dimensions & shapes may vary



# STANDARD CONSOLES

models & bench top dimensions

## Ultimate 3L Series

- model 2216
- model 2416
- model 2617

(straight options available)

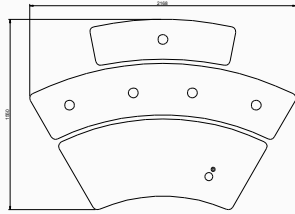

model 2216  
(bench top size 2200x1550)

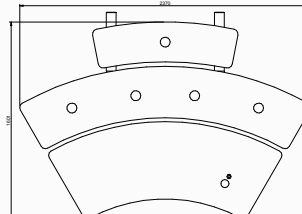

model 2416  
(bench top size 2400x1600)

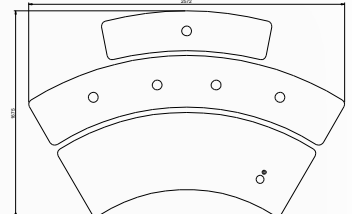

model 2617  
(bench top size 2600x1700)

## Executive Series

- model 2110
- model 2310
- model 2510

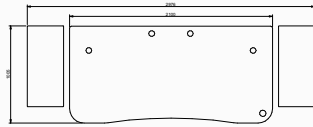

model 2110  
(bench top size 2100x1000)

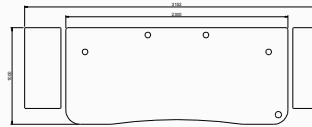

model 2310  
(bench top size 2300x1000)

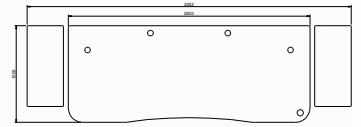

model 2510  
(bench top size 2500x1000)

## Viewline Series

- model 1690
- model 1810

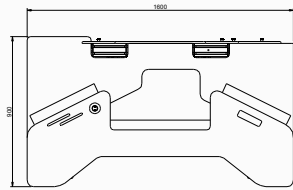

model 1690  
(bench top size 1600x900)

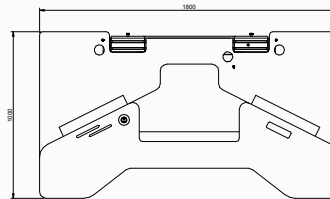

model 1810  
(bench top size 1800x1000)

All dimensions are approximate only. Actual dimensions & shapes may vary

# COLOURS & TEXTURES

### Standard Colours



### Standard Textured





# CUSTOM DESIGNED CONSOLES

## EXAMPLE 1

Custom Variations Available On Request  
SEE PAGE 26



## EXAMPLE 2

Custom Variations Available On Request  
SEE PAGE 27



## EXAMPLE 3

Custom Variations Available On Request  
SEE PAGE 28



## EXAMPLE 4

Custom Variations Available On Request  
SEE PAGE 30







# CUSTOM DESIGNED CONSOLES

## EXAMPLE 5

Custom Variations Available On Request  
SEE PAGE 32



## EXAMPLE 6

Custom Variations Available On Request  
SEE PAGE 34



## EXAMPLE 7

Custom Variations Available On Request  
SEE PAGE 36



## EXAMPLE 8

Custom Variations Available On Request  
SEE PAGE 38





# CUSTOM DESIGNED CONSOLES

EXAMPLE 1  
Custom Variations Available On Request



AME specialises in custom designed, made to order consoles. Contact us now for a tailored quote & design.



# CUSTOM DESIGNED CONSOLES

EXAMPLE 2  
Custom Variations Available On Request



AME specialises in custom designed, made to order consoles. Contact us now for a tailored quote & design.

**ACTIVCONSOLE**  
ERGONOMIC TECHNOLOGY

by AME System



# CUSTOM DESIGNED CONSOLES

EXAMPLE 3  
Custom Variations Available On Request



AME specialises in custom designed, made to order consoles. Contact us now for a tailored quote & design.



# CUSTOM DESIGNED CONSOLES

EXAMPLE 4  
Custom Variations Available On Request



AME specialises in custom designed, made to order consoles. Contact us now for a tailored quote & design.

**ACTIVCONSOLE**  
ERGONOMIC TECHNOLOGY

by AME System





---

# CUSTOM DESIGNED CONSOLES

---

EXAMPLE 5  
Custom Variations Available On Request



---

AME specialises in custom designed, made to order consoles. Contact us now for a tailored quote & design.

---





# CUSTOM DESIGNED CONSOLES

EXAMPLE 6  
Custom Variations Available On Request



AME specialises in custom designed, made to order consoles. Contact us now for a tailored quote & design.

**ACTIVCONSOLE**  
ERGONOMIC TECHNOLOGY

by AME System



# CUSTOM DESIGNED CONSOLES

EXAMPLE 7  
Custom Variations Available On Request

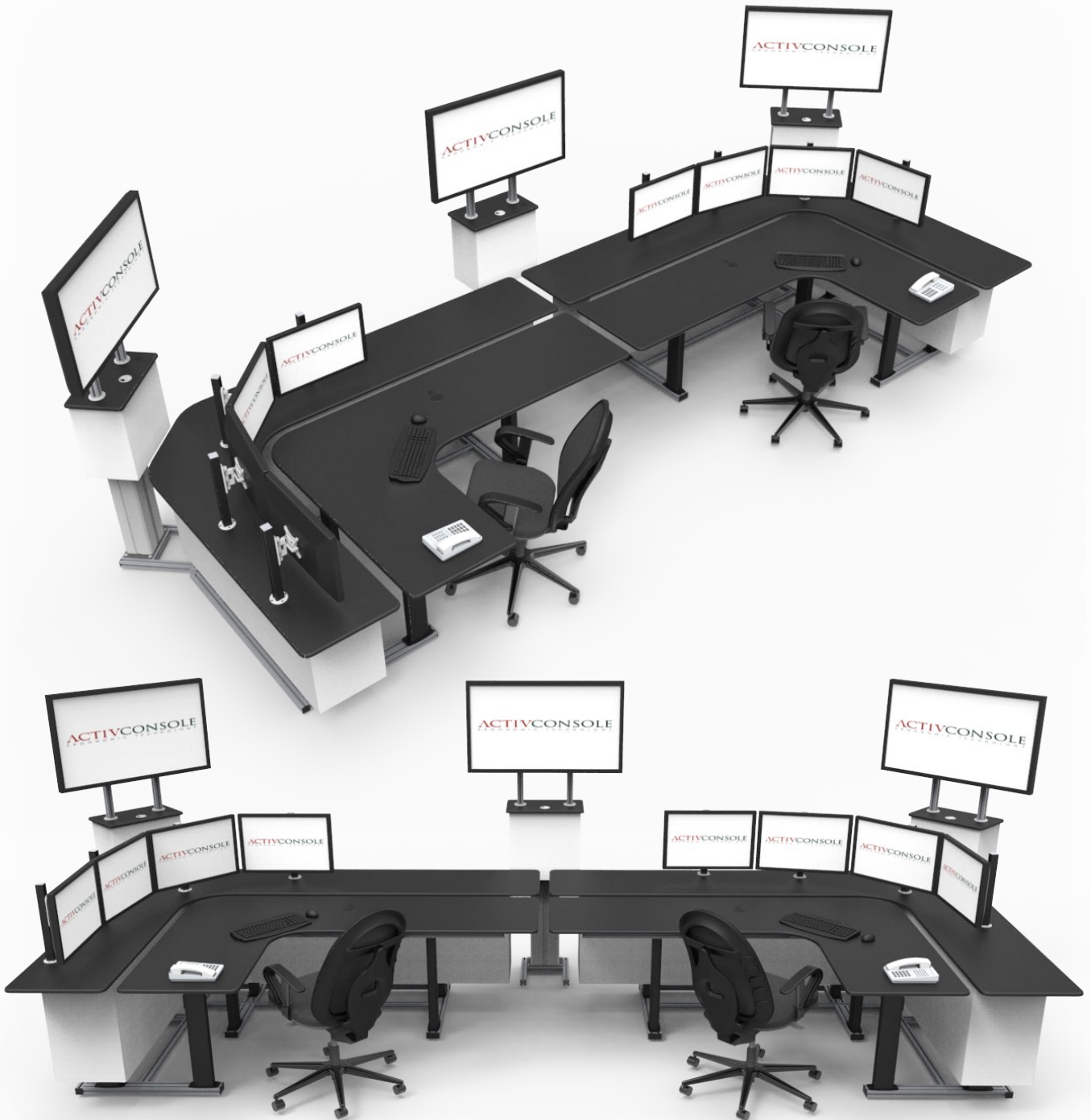

AME specialises in custom designed, made to order consoles. Contact us now for a tailored quote & design.



# CUSTOM DESIGNED CONSOLES

EXAMPLE 8  
Custom Variations Available On Request



AME specialises in custom designed, made to order consoles. Contact us now for a tailored quote & design.

**ACTIVCONSOLE**  
ERGONOMIC TECHNOLOGY

by AME System



## CONSOLE ACCESSORIES

### MONITOR POLES

- △ 40x40 Single Pole
- △ 40x80 Double Pole
- △ 80x80 Heavy Duty Pole

SEE PAGE 36



### MOUNTING BRACKETS

- △ Pivot Bracket
- △ Horizontal Monitor Arm

SEE PAGE 37



### MONITOR MOUNTING ARMS

- △ Galaxy Monitor Arm
- △ Force Heavy Duty Monitor Arm
- △ Guardian Monitor Arm

SEE PAGES 38-40



### LARGE DISPLAY MOUNTING BRACKETS

- △ H-frame for Large Displays
- △ Configurable Video Wall Mounting Kit

SEE PAGE 41





# CONSOLE ACCESSORIES

## FOOTREST & PC HOLDERS

- Λ Manually Adjustable Footrest
- Λ Single PC Holder
- Λ Double PC Holder

SEE PAGE 42

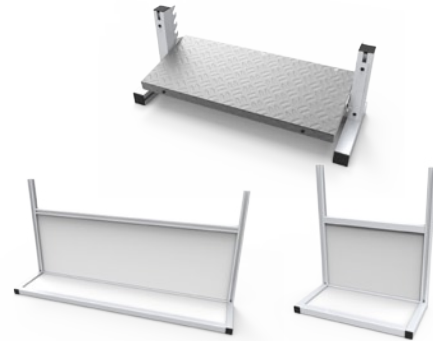

## SOFT WIRING SYSTEM

- Λ Personal Power and Data Hubs (PPDH)
- Λ Soft Wiring Systems

SEE PAGE 43



## CABLE MANAGEMENT SYSTEMS

- Λ Cable Chain
- Λ Cable Ducting
- Λ Cable Grips

SEE PAGE 44

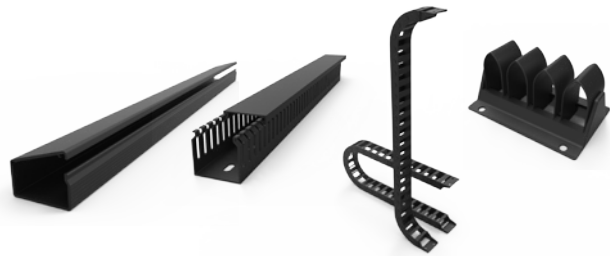

## OPERATOR CHAIRS

- Λ Light Duty Operator Chair
- Λ Heavy Duty 24/7 Operator Chair

SEE PAGE 45





## MONITOR POLES

### 40x40

40x40/180 Profile

Height: 360mm  
Colour: Natural Anodised  
Flange: Silver Grey  
Part Number: 860 103

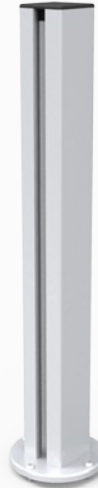

40x40 post

### 40x80

40x80 profile

Height: 760mm  
Colour: Natural Anodised  
Flange: Silver Grey  
Part Number: 860 107



40x80 post

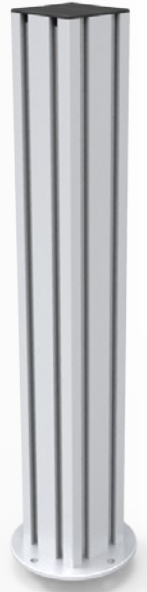

80x80 post

### 80x80 (Heavy Duty)

80x80 profile

Height: 700mm  
Colour: Natural Anodised  
Flange: Silver Grey  
Part Number: 860 212

### Mounting Options Bolt Through Mounting Kit Only

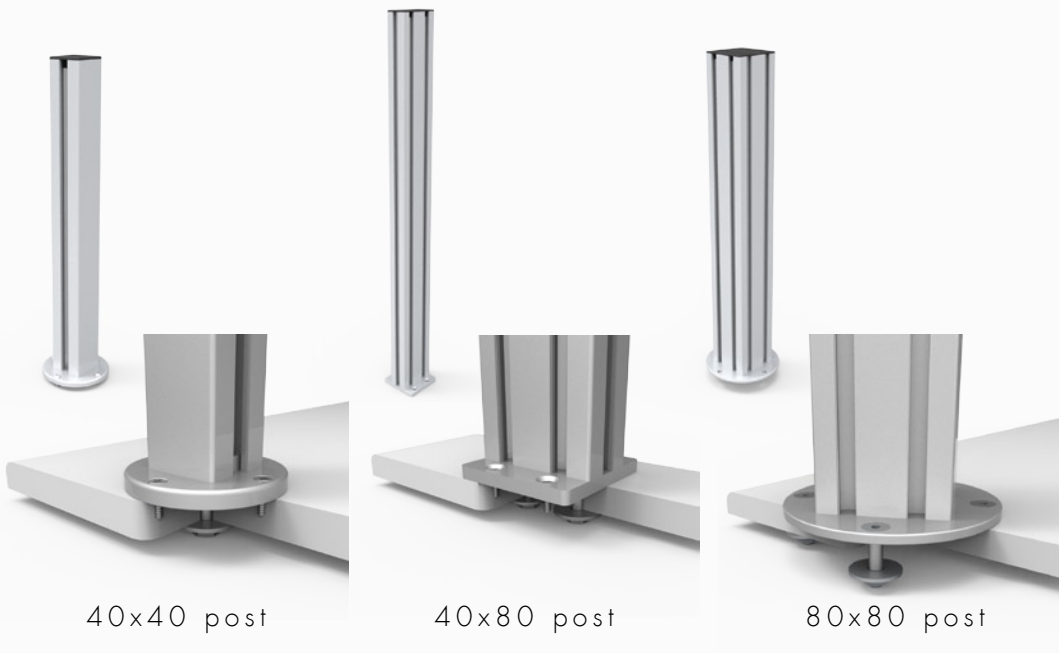

40x40 post

40x80 post

80x80 post





## MOUNTING BRACKETS

### Pivot Bracket

Material: Aluminium Cast  
Colour: Black  
Vertical Rotation: 9° range  
Horizontal Rotation: 9° range  
Max Weight: 10.5kg  
VESA mount: 75mm and 100mm  
Part Number: 860 103

#### Features:

- △ Quick release plate for easy monitor attachment and removal
- △ Simple and secure vertical adjustment
- △ Mounts easily to monitor pole products

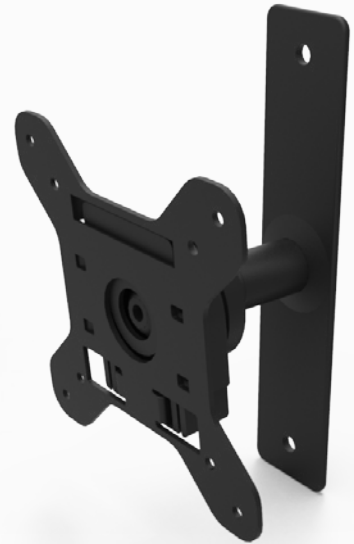

### Horizontal Monitor Arm

Material: Aluminium Cast  
Colour: Black  
Vertical Tilt: 9° range  
Horizontal Rotation: 180° range  
Max Reach: 320mm  
Max Weight: 10.5kg  
VESA mount: 75mm and 100mm  
Part Number: 860 212

#### Features:

- △ Ideal for multilevel LCD displays
- △ Smooth and easy horizontal adjustment with simple
- △ Secure vertical adjustment
- △ Mounts easily to monitor pole products





## MONITOR ARMS

### Galaxy Monitor Arm

Material:	Aluminium Cast
Colour:	Silver Grey
Vertical Rotation:	160° range
Horizontal Rotation:	360° range
Vertical Reach:	290mm
Horizontal Reach:	570mm
Max Weight:	13.5kg
VESA mount:	75mm and 100mm
Part Number:	860 256

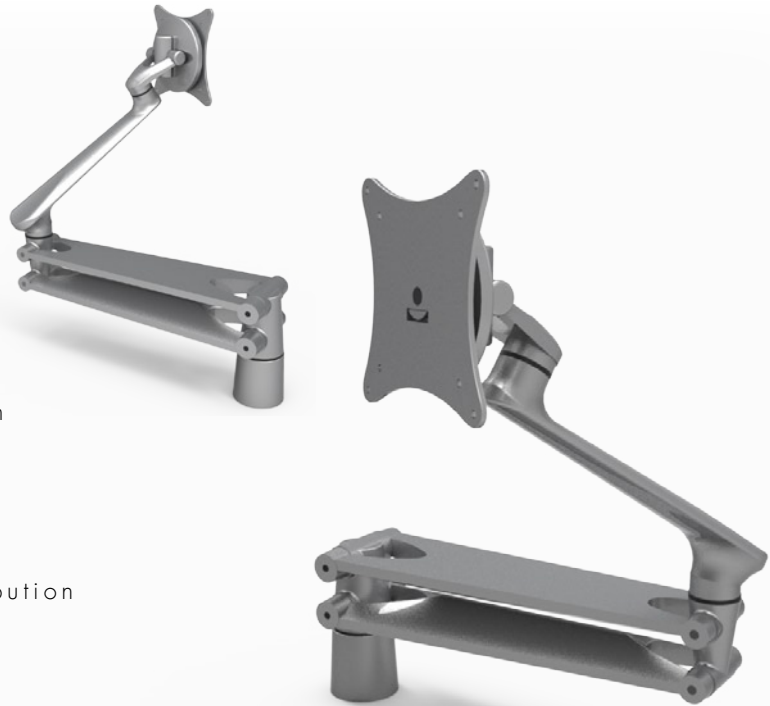

### Features:

- Λ Integral gas spring
- Λ Counter balanced weight distribution
- Λ Full monitor articulation
- Λ Security lock screw
- Λ Quick release plate for easy monitor attachment and removal
- Λ Maximum space utilisation

### Mounting Options

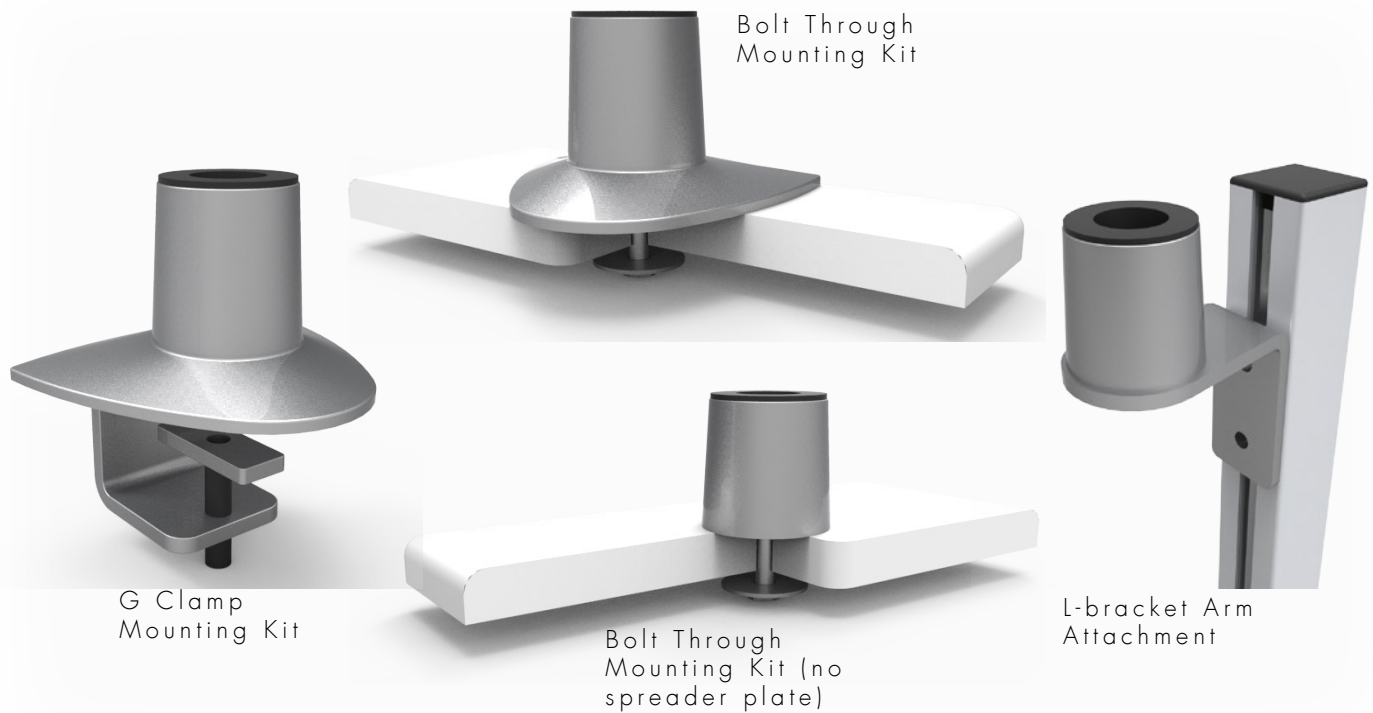



## MONITOR ARMS

### Force Heavy Duty Monitor Arm

Material:	Aluminium Cast
Colour:	Silver Grey/Black
Vertical Rotation:	200° range
Horizontal Rotation:	360° range
Vertical Reach:	460mm
Horizontal Reach:	660mm
max weight:	20kg
VESA mount:	75mm and 100mm
Part Number:	860 150



### Features:

- Λ Integral gas spring
- Λ Counter balanced weight distribution
- Λ Full monitor articulation
- Λ Security lock screw
- Λ Internal hidden cable management
- Λ Maximum space utilisation

### Mounting Options

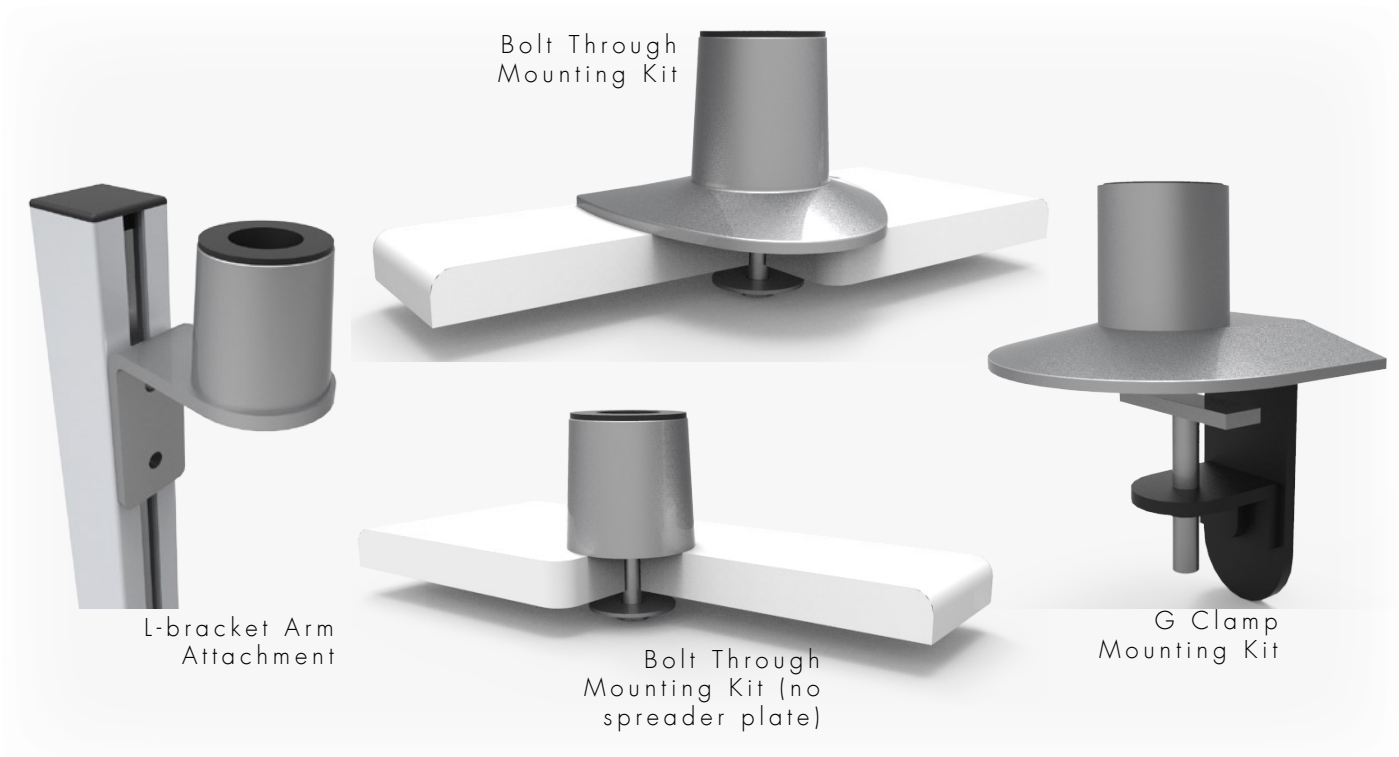



## MONITOR ARMS

### Guardian Monitor Arm

Material:	Aluminium Cast
Colour:	Black/White Inserts
Horizontal Rotation:	360° range
Vertical Rotation:	180° lock out feature
Vertical Reach:	296mm
Horizontal Reach:	634mm
Max Weight:	9kg
VESA mount:	75mm and 100mm
Part Number:	860 050

### Features:

- △ Latest spring technology
- △ 180° lock out feature to protect walls and screens
- △ Quick release plate for easy monitor attachment and removal
- △ Internal hidden cable management



### Mounting & Accessory Options



G Clamp Mounting Kit

Bolt Through Mounting Kit

Dual USB Attachment



## LARGE DISPLAY MONITOR BRACKETS

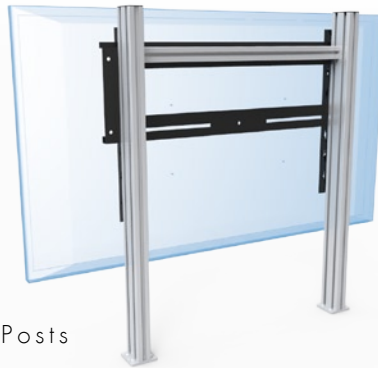

### H-Frame

Material: Steel & Aluminium Posts  
Colour: Black/Silver  
Universal Width: 180-800mm  
Universal Height: 125-500mm  
Max Weight: 91kg  
VESA mount: 600x200, 600x400, 800x200,  
800x400, Universal  
Part Number: 860 185



### Features:

- Λ Ideal for mounting monitors 32" and above
- Λ Low profile display (39mm from wall)
- Λ Configurable pole width (if required)

### Configurable Video Wall Mounting Kit

Material: Steel  
Colour: Black  
Plate Widths: 1000 & 1600mm  
Support Height: 480mm  
Tilt range: 11° range (with spacer)  
Max Weight: 165kg  
VESA mount: Unlimited up to 400mm VESA height  
Part Number: 860 190

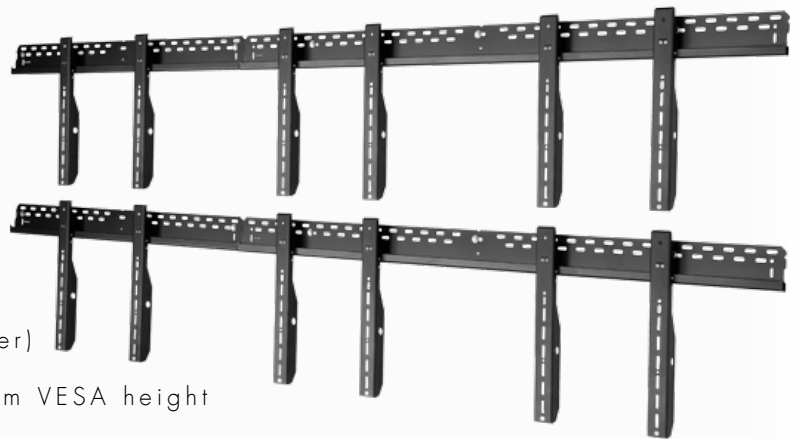

### Features:

- Λ Modular design gives you the freedom to expand your set as necessary
- Λ Simple hook on installation system
- Λ Security fixing points for each display



## FOOTRESTS AND PC HOLDERS

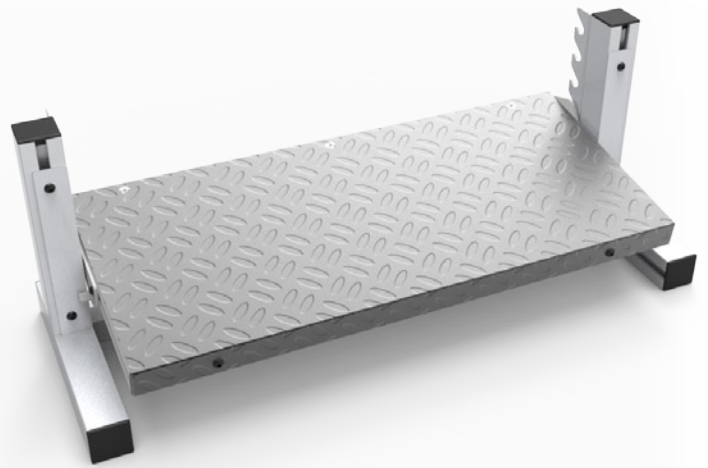

### Manually Adjustable Footrest

Material:	Aluminium Frame 2mm Checker Plate
Colour:	Black/Silver
Inclination:	11° angle (fixed)
Vertical Height Range:	50-190mm
Foot Plate Dimensions:	595x265mm
Part Number:	860 120

### Features:

- △ Manually height adjustable
- △ Ideal for sitting and standing
- △ Heavy duty construction

### PC Holder Range

Material:	Aluminium Frame Decorwood Panels
Colour:	Black/White
Sizes:	560x290, 1360x260, Custom Sizes Available
Max PC Size:	200x440x500mm (WxDxH)
Part Number:	860 220

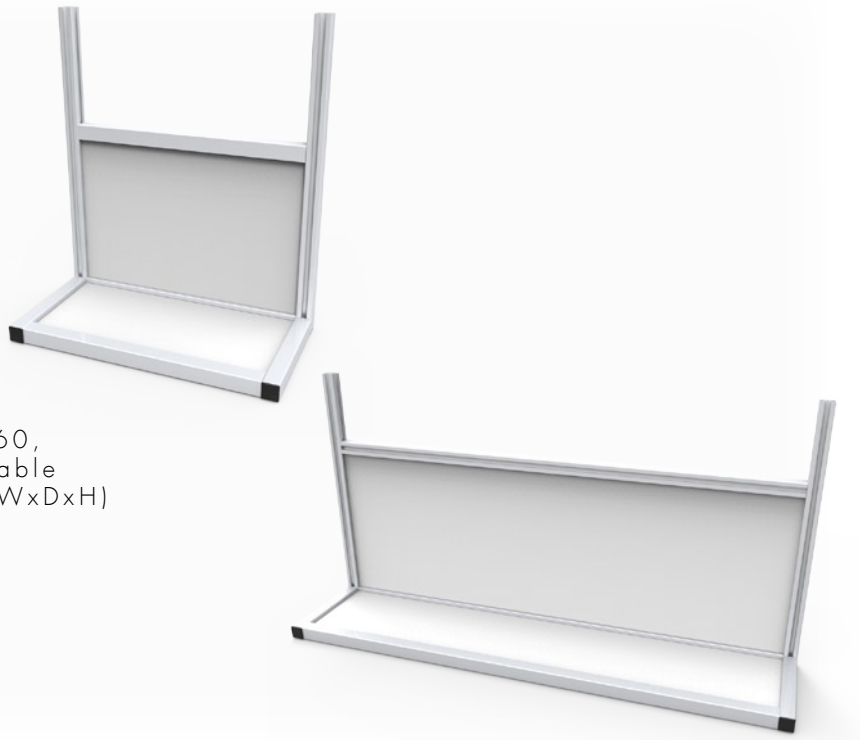

### Features:

- △ Customisable sizing available
- △ Side and rear mount options
- △ Sturdy aluminium frame





## POWER MODULES

### AS/NZ Soft Wiring System

Material: Polycarbonate Body  
Colours: White/Black/Red  
Part Number: N/A



#### Features:

- ⚠ UPS and non-UPS systems
- ⚠ All sockets are auto switched softwired GST connectors
- ⚠ Maximum 10 outlets per circuit (non - UPS only)
- ⚠ Maximum 24 outlets per circuit (UPS only)
- ⚠ Power modules available with 2 or 4 outlets
- ⚠ Thermal overload on starter cable (non-UPS systems only)
- ⚠ Variety of interconnecting cables and exit (termination) plug options available

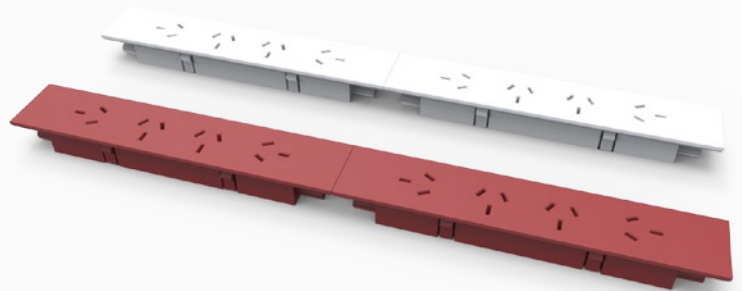

### Personal Power & Data Hub (PPDH)

Material: Polycarbonate Body  
Colour: Black/White  
Part Number: N/A



#### Features:

- ⚠ Easy operator access
- ⚠ Configurable - 2 blank spaces for several different configurations (default 1 USB, 1 blank)
- ⚠ Supports USB, RJ45, HDMI and audio
- ⚠ Screw into a standard 80mm hole
- ⚠ Fits surface thickness of 1-40mm
- ⚠ Simple screw nut (no tools required)

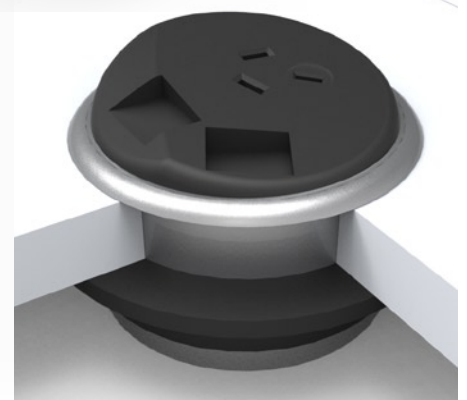



## CABLE MANAGEMENT SYSTEMS



### Cable Chain

Material: Polycarbonate  
Colour: Black  
Length: Custom Sizes & Lengths

- △ Available for power & data
- △ Internal separation dividers



### Cable Grip

Material: Flexible Polycarbonate  
Colour: Black  
Grippers: Available with 3 or 4 cable grippers

- △ For use with for power & data

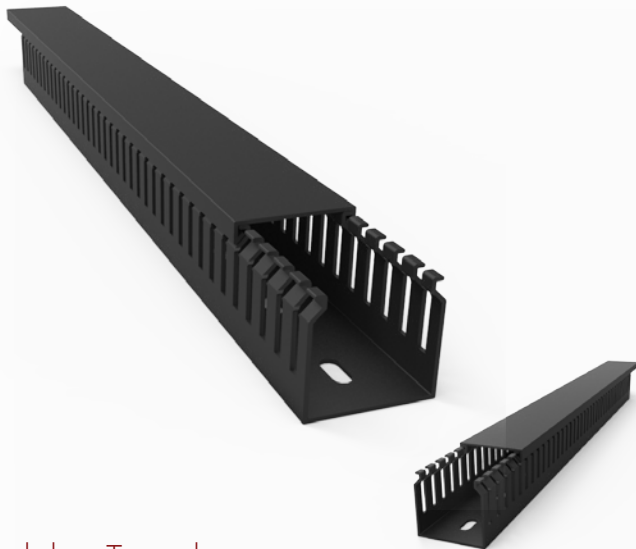

### Cable Trunk

Material: Polycarbonate  
Colour: Black  
Length: Max 2m length



### Cable Duct

Material: Polycarbonate  
Colour: Black  
Length: Max 2m length



## OPERATOR CHAIRS

### Light Duty Operator Chair

Seat Foam:	Classic Seat
Seat Width:	480mm
Seat Height:	450-580mm
Seat Depth:	450mm
Back Height (low):	480mm
Back Height (high):	600mm
Arm Height:	160mm (from seat)

- △ Standard gas lift
- △ GECA approved product
- △ Posture support system
- △ 3 lever ergo light mechanism
- △ Classic seat
- △ 5 star base
- △ Polished aluminium arms
- △ Maximum Weight Rating: 100kg
- △ Chair Warranty: 5 years



### Heavy Duty 24/7 Operator Chair

Seat Foam:	Heavy duty dual density
Seat Width:	560mm
Seat Height:	470-600mm
Seat Depth:	540mm
Back Height (low):	610mm
Back Height (high):	670mm
Arm Height:	160mm (from seat)

- △ Standard heavy duty gas lift
- △ GECA approved product
- △ 3 lever ergo heavy duty mechanism
- △ Single click ratchet system
- △ Heavy duty dual density seat
- △ Heavy duty polished aluminium base
- △ Heavy duty polished aluminium arms
- △ Maximum Weight Rating: 200kg
- △ Chair Warranty: 5 years
- △ H2 head rest
- △ Heavy duty dual density deep/wide seat







# CALENDAR PLANNER

## JANUARY

1 2 3 4 5 6 7  
8 9 10 11 12 13 14  
15 16 17 18 19 20 21  
22 23 24 25 26 27 28  
29 30 31

## FEBRUARY

1 2 3 4 5 6 7  
8 9 10 11 12 13 14  
15 16 17 18 19 20 21  
22 23 24 25 26 27 28  
29

## MARCH

1 2 3 4 5 6 7  
8 9 10 11 12 13 14  
15 16 17 18 19 20 21  
22 23 24 25 26 27 28  
29 30 31

## APRIL

1 2 3 4 5 6 7  
8 9 10 11 12 13 14  
15 16 17 18 19 20 21  
22 23 24 25 26 27 28  
29 30

## MAY

1 2 3 4 5 6 7  
8 9 10 11 12 13 14  
15 16 17 18 19 20 21  
22 23 24 25 26 27 28  
29 30 31

## JUNE

1 2 3 4 5 6 7  
8 9 10 11 12 13 14  
15 16 17 18 19 20 21  
22 23 24 25 26 27 28  
29 30

## JULY

1 2 3 4 5 6 7  
8 9 10 11 12 13 14  
15 16 17 18 19 20 21  
22 23 24 25 26 27 28  
29 30 31

## AUGUST

1 2 3 4 5 6 7  
8 9 10 11 12 13 14  
15 16 17 18 19 20 21  
22 23 24 25 26 27 28  
29 30 31

## SEPTEMBER

1 2 3 4 5 6 7  
8 9 10 11 12 13 14  
15 16 17 18 19 20 21  
22 23 24 25 26 27 28  
29 30

## OCTOBER

1 2 3 4 5 6 7  
8 9 10 11 12 13 14  
15 16 17 18 19 20 21  
22 23 24 25 26 27 28  
29 30 31

## NOVEMBER

1 2 3 4 5 6 7  
8 9 10 11 12 13 14  
15 16 17 18 19 20 21  
22 23 24 25 26 27 28  
29 30

## DECEMBER

1 2 3 4 5 6 7  
8 9 10 11 12 13 14  
15 16 17 18 19 20 21  
22 23 24 25 26 27 28  
29 30 31

---

---

---

---

---

---

---

---

---

---

# ACTIVCONSOLE

ERGONOMIC TECHNOLOGY

[www.activconsole.com](http://www.activconsole.com)



AME System Pty Ltd  
3/4 Garden Road  
Clayton Victoria 3168  
Australia  
Ph: +613 9574 8044  
Fax: +613 9574 8744  
[sales@amesystem.com.au](mailto:sales@amesystem.com.au)  
[www.amesystem.com.au](http://www.amesystem.com.au)

#### Terms of use

The user is responsible for determining the suitability of AME System products for specific applications. AME System takes care in providing accurate and up-to-date information on its products. However, due to continuous development in order to improve its products, AME System products are subject to frequent modifications and changes without prior notice. Therefore, AME System cannot guarantee the correct status of information on its

products contained within this brochure. Whilst AME System uses best efforts to fulfill orders, AME System cannot guarantee the availability of any particular product. AME System reserves the right to discontinue to sale of any product displayed on its website or listed in its catalogue or other written material drawn up by AME System at any time. AME System reserves the right to adjust pricing as necessary.